

Name: _____

A.F.C.Q.B.





Health	8	7	6	5	4 -3 AP	3 -4 AP	2 -5 AP	1 -6 AP
--------	---	---	---	---	------------	------------	------------	------------

Rifle: Reload 1AP		
30	29	28
27	26	25
24	23	22
21	20	19
18	17	16
15	14	13
12	11	10
9	8	7
6	5	4
3	2	1 Reload

Weapon In Use
Place weapon card here.
Rifles require two hands to fire
1 AP to change Weapons

Mark firing mode with a marker

At end of round figure:

Is still moving	Stays in position
Gear in Use	
 Gas Mask	 NVG
 Flashlight	 Rope

Action Points	
10	5
9	4
8	3
7	2
6	1

Ammo Pouch

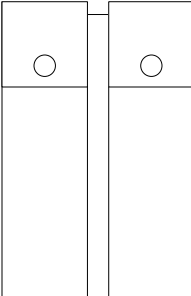

Needed to carry ammo:
2 rifle mags, 2 Auto Pistol mags,
6 Revolver speedloads, 16 shotgun
rounds, 6 40mm grenades

Auto Pistol: Reload 1AP		
12	11	10
9	8	7
6	5	4
3	2	1 Reload

Revolver; Reload 1AP		
6	5	4
3	2	1 Reload

40mm: Reload 2 AP		
6	5	4
3	2	1 Reload

Shotgun: 2 AP to reload all, 1 AP for 2			
8	7	6	5
4	3	2	1 Reload

Light conditions		
Day	Low -1 to hit Gets Dark 1D6	Dark -2 to hit
1-2	3-4	5-6

Silenced Weapons: Target figure may not return fire with a Snapshot unless shooter is in full view.

Action results table: Use 1D6						
Range:	Same area	1	2	3	4	5
To Hit 1=Miss	2~6	2~5	2~4	2~3	2~3	6

Target Mods:	Target prone	Partial cover	Full cover	Target or Shooter moving: -1 to hit
	-2	-1	-2	
Shooter Mods:	Kneeling	Prone	Gas effects	Both Shooter and Target moving: -2 to hit
	+1	+2	-2	

Auto / 3 rnd burst hit results. Round down					
Same area	1	2	3	4	5
1 100%	1 100%	1-3 2/3	1-2 2/3	1 2/3	1 2/3
	2-4 2/3	4-5 1/3	2-4 1/3	2-4 1/3	2-3 1/3
	5 1/3	6 0%	6 0%	5-6 0%	4-6 0%
	6 0%				

Grenades: Throw / Shoot using 'Action Results table', for each Pip missed by, Grenade lands 1 away from Target space.
1D6: 1-2 falls short, 3-6 overshoots

Cargo Pockets

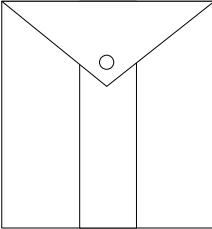

1 pocket holds 1 small item